

TYPE: 2PSJSXY0-followed by alphanumeric codes

Description: Ø22.5 Series Joystick Pushbutton



General Characteristics:

These are manually operated switches for installation in control panel & portable control equipment. They are used in steel, construction industry, machine tools, transport, conveyors, ware housing, studio, radio & cable control & cranes. They are used wherever motion sequences to actuation directions are controlled by hand. They are ideal for raising, lowering, moving to left or right. The switching elements are actuated by the joystick being moved out of intermediate position.

Note:

The product is supplied as a single unit & not intended to be used without the special contact block/s attached to it. Product is factory fitted & warranty would be void if factory fitment is tampered. Standard contact elements (e.g. Model nos S1, S2... etc) cannot be used with this.

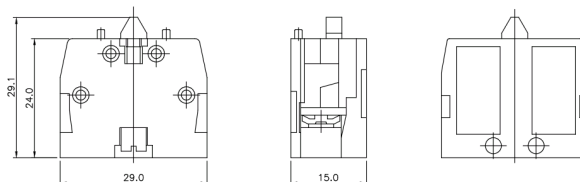

Mechanical Characteristics

Terminal Capacity

: Maximum 2X1.5mm² or 1X 2.5mm²

: Minimum 1X0.5mm²

Terminal marking

: 3 4

Terminal Torque

: 0.8N.m

Operation

: Self-wiping, slow break

Mechanical life

: over 0.1 million operations

Ambient

: -25°C to +70°C

Storage

: -25°C to +40°C for 24months stored in clean & dry surrounding

Mounting

: Can be mounted Vertical or Horizontal as required

Fixing Centers

35mm X 90mm (2P/2PSR) A

90mm X 90mm (4P/4PSR) B

A

B

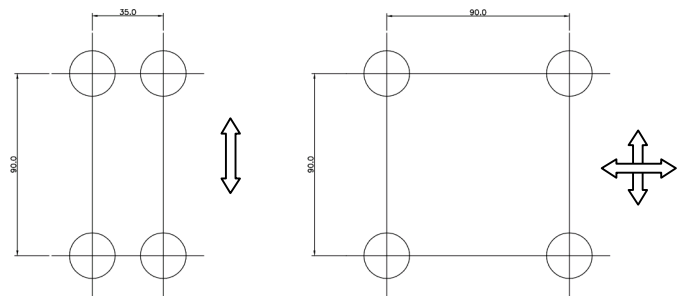

Mounting panel thickness: 1mm to 6mm

: with 2 elements: 120X40X30

: with 4 elements: 144X40X30

Overall Dimensions (LXBXH)

2PSJSXY0-2P/2PSR

2PSJSXY0-4P/4PSR

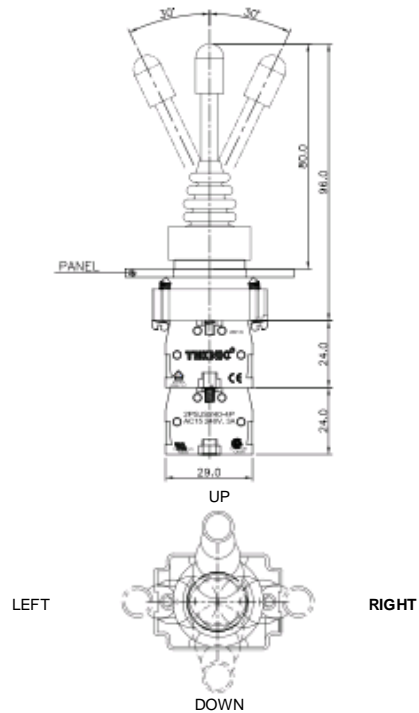
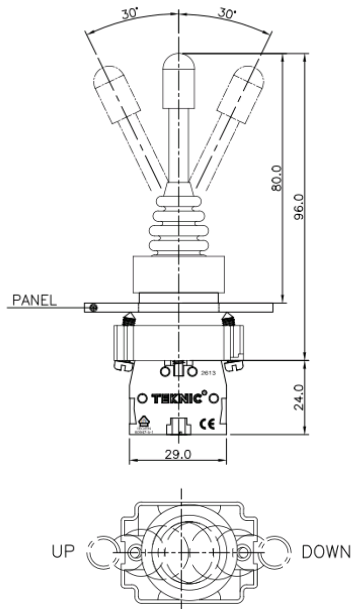

Electrical Characteristics:

Make & Break Capacity	: AC 15 3A, 240 V AC DC 13 0.5A, 110V DC with a time constant of 300ms A600, Q600
Rated insulation voltage	: 500V
Rated thermal current	: 10A
Short circuit protection	: 10A HRC cartridge fuse, rated for resistive loading
Dielectric Test	: 2.5KV
Approvals regarding the material Polymeric parts	: UL-Recognized material

Ordering codes for 2PSJSXY0-2P/4P/2PSR/4PSR

The ordering code for each product is mentioned on the product as well as the primary packing box.

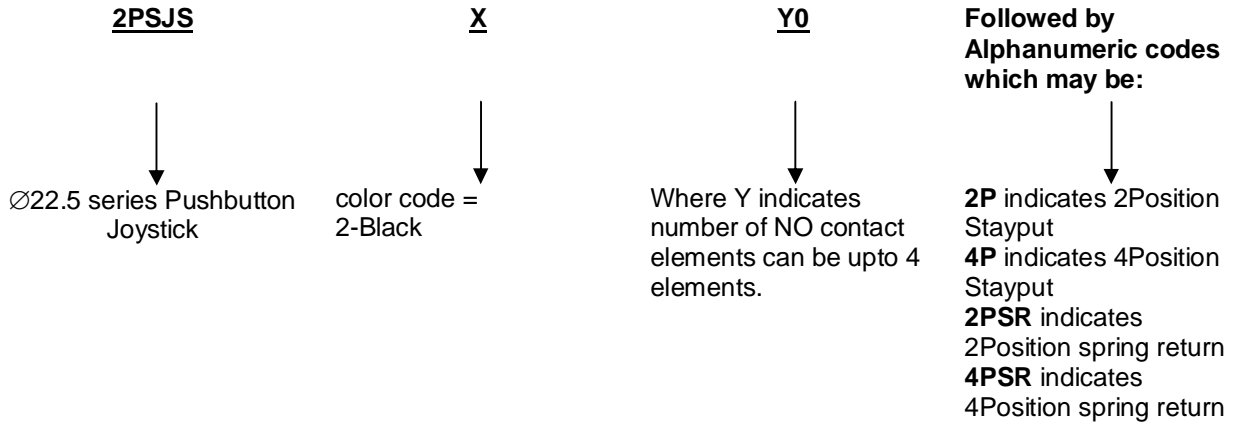

Mounting Instructions

Safety regulations: This unit may be installed & commissioned by trained personnel who are familiar with current regulation for health & safety at work & accident prevention. Ensure local regulations are met especially those relating to safety. This is for use on flat surface, IP65 & type 4X, 12 enclosure. Ensure that this pushbutton switch will operate fully after installation. Failure to follow these will result in malfunctioning of the switch & may cause damage to equipment or accident.

To install:

1. Open the top sub assembly by rotating it in anticlockwise direction

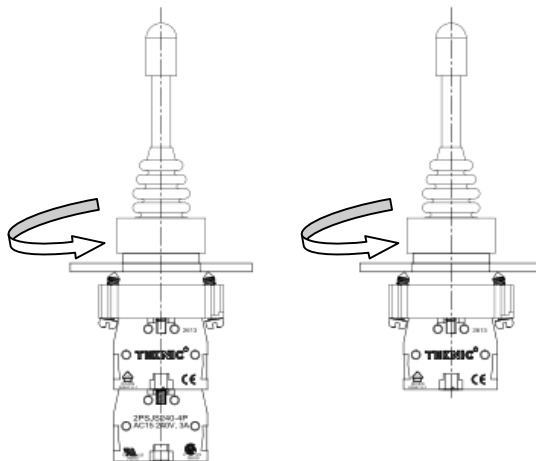

Mounting Instructions (Contd.)

2. Insert the JS bracket with element assembly from back of the panel of Ø22.5 cutout.

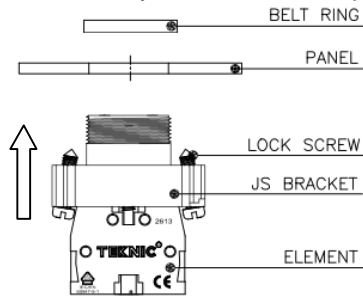

3. Ensure the belt ring is assembled from above the panel. **Fully tighten the top sub assembly by rotating clockwise.**

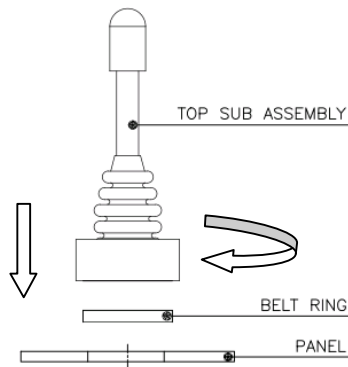

4. Tighten the lock screws in clockwise direction with a torque of 1.2Nm (max)

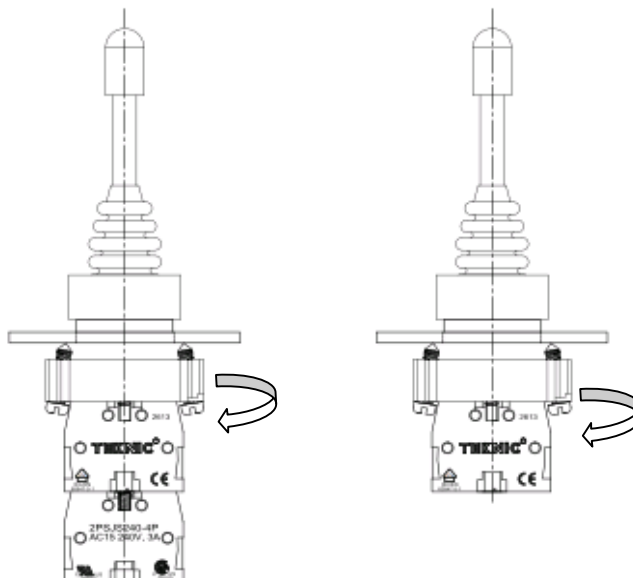

5. Check to see if the handle operates in 2P/4P directions, as applicable.

To uninstall:

1. Open the lock screws fully by turning anticlockwise direction
2. Rotate the top sub assembly in anticlockwise direction & the sub assemblies separates out

